



7DU/7EU Dimension

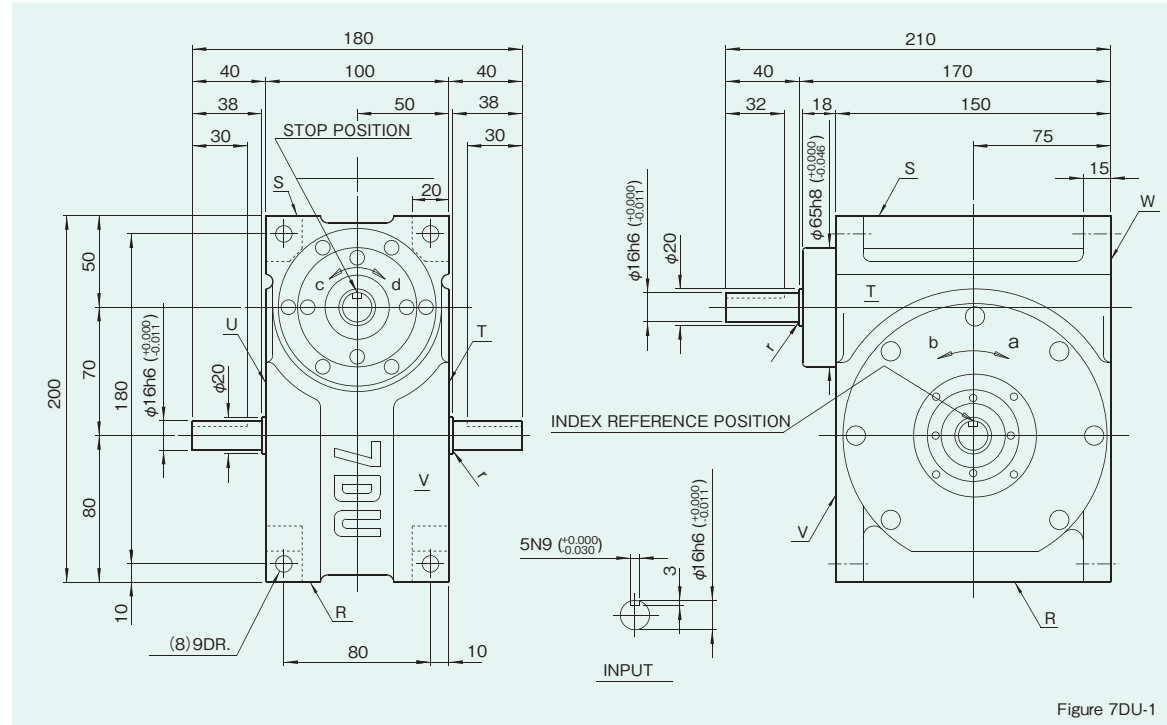
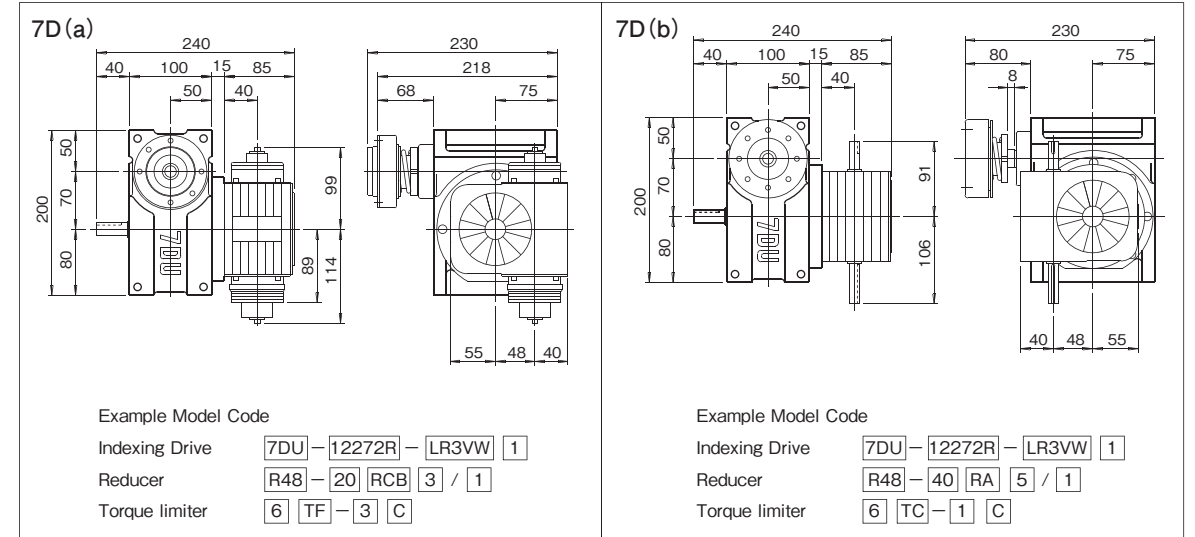

Figure 7DU-1

Mounted accessories



Precautions

- Models 7DU and 7EU can be equipped with reducers R48.
- The reducer can be mounted in 16 different positions as shown on page of Reducer.
- Models 7DU and 7EU can be equipped with torque limiters 6TF and 6TC.
- Torque limiter TC-types require a collar for mounting.

Mounting hole locations

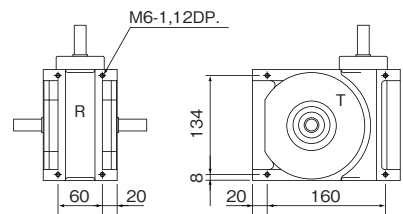

Dimension of R,S,T, and U surface

Locations of oil plug, etc., and oil capacity

Figure 7DU-3

Mounting position	1	2	3	4	5	6
Location						
Oil capacity (ℓ)	0.5	0.45	0.55	0.55	0.4	0.5

Precautions

- Each point indicated in the mounting positions shown in Figure 7DU-3 represents (starting at top) the oil plug (PT3/8), oil level (VA-01), and drain (PT3/8).
- The mounting positions correspond to code i for the indexing, oscillating, and roller drives.
- The oil levels indicated in Figure 7DU-3 are given in general figures and will differ according to the profile of the cam and the number of cam followers.

Specifications

Table 7DU-1

Item	Symbol	Unit	Value	Item	Symbol	Unit	Value	Item	Symbol	Unit	Value
Output allowable axial load	P <sub>1</sub>	N	882	Input allowable axial load	P <sub>4</sub>	N	980	Indexing accuracy (1 DWELL)		sec	±72
Output allowable radial load	P <sub>2</sub>	N	637	Input maximum repetitious bending force	P <sub>5</sub>	N	931				
Output static torque	T <sub>s</sub>	N·m	Refer to Torque Capacity Table	Input maximum repetitious allowable torque	P <sub>6</sub>	N·m	58.8				
Output torsional rigidity	K <sub>1</sub>	N·m/rad	3.53×10 <sup>3</sup>	Input torsional rigidity	K <sub>2</sub>	N·m/rad	4.12×10 <sup>3</sup>				
Output inertia	J <sub>0</sub>	kg·m <sup>2</sup>	6.5×10 <sup>-5</sup>	Input inertia	J <sub>1</sub>	kg·m <sup>2</sup>	3.75×10 <sup>-3</sup>	Repetitive accuracy		sec	35
Output allowable bending moment	P <sub>3</sub>	N·m	24.5					Product weight		kg	16
								Housing color		Gray	

Note : Input inertia : J is calculated in dwell.

(1N=0.102kgf)

## 8DU/8EU Dimensions

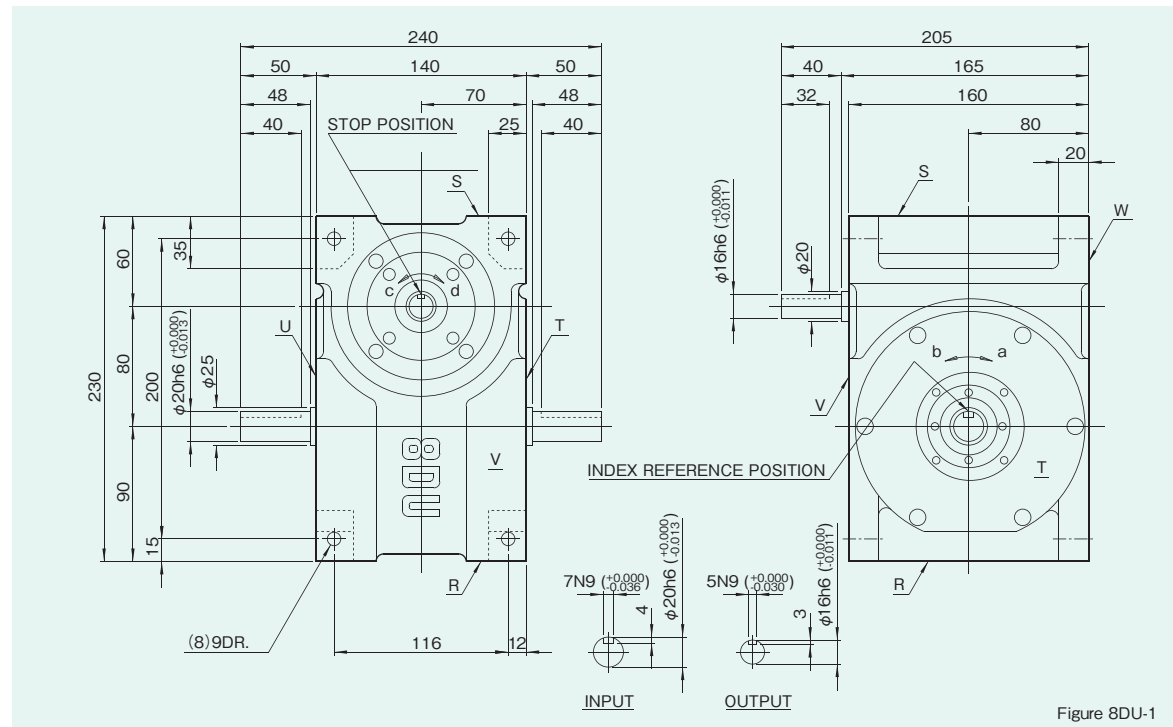

Figure 8DU-1

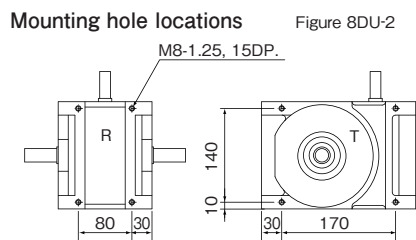

Figure 8DU-2

Dimensions of R,S,T, and U surface

### Precautions

- Case of mounting position 5 and 6, S surface has 3holes.

### Locations of oil plug, etc., and oil capacity

Figure 8DU-3

Mounting position	1	2	3	4	5	6
Location						
Oil capacity(ℓ)	0.9	0.8	1	1	0.7	0.9

### Precautions

- Each point indicated in the mounting positions shown in Figure 8DU-3 represents (starting at top) the oil plug (PT3/8), oil level (VA-01), and drain (PT3/8).
- The mounting positions correspond to code i for the indexing, oscillating, and roller drives.
- The oil levels indicated in Figure 8DU-3 are given in general figures and will differ according to the profile of the cam and the number of cam followers.

### Specifications

Table 8DU-1

Item	Symbol	Unit	Value	Item	Symbol	Unit	Value	Item	Symbol	Unit	Value
Output allowable axial load	P <sub>1</sub>	N	1274	Input allowable axial load	P <sub>4</sub>	N	1372	Indexing accuracy (1 DWELL)		sec	±60
Output allowable radial load	P <sub>2</sub>	N	882	Input maximum repetitious bending force	P <sub>5</sub>	N	1862				
Output static torque	T <sub>s</sub>	N·m	Refer to Torque Capacity Table	Input maximum repetitious allowable torque	P <sub>6</sub>	N·m	93.1				
Output torsional rigidity	K <sub>1</sub>	N·m/rad	4.80×10 <sup>3</sup>	Input torsional rigidity	K <sub>2</sub>	N·m/rad	8.82×10 <sup>3</sup>				
Output inertia	J <sub>0</sub>	kg·m <sup>2</sup>	1.95×10 <sup>-4</sup>	Input inertia	J <sub>1</sub>	kg·m <sup>2</sup>	4.25×10 <sup>-3</sup>	Repetitive accuracy		sec	30
Output allowable bending moment	P <sub>3</sub>	N·m	24.5					Product weight		kg	30
								Housing color		Gray	

Note : Input inertia : J is calculated in dwell.

(1N=0.102kgf)

## Mounted accessories

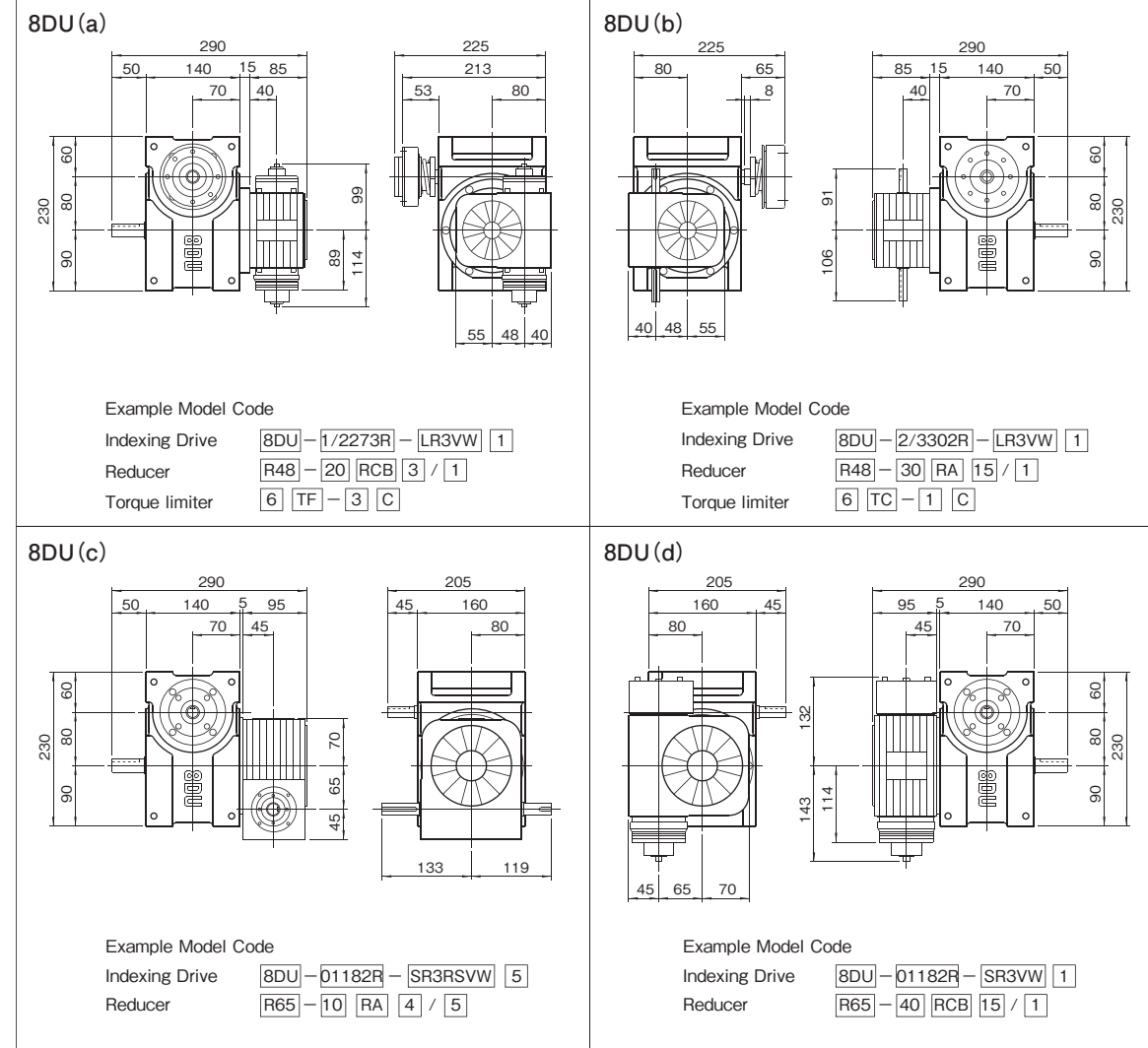

### Precautions

- Models 8DU and 8EU can be equipped with reducers R48 and R65.
- The reducer can be mounted in 16 different positions as shown on page of Reducer.
- Models 8DU, 8EU can be equipped with torque limiters 6TF, 6TC.
- Torque limiter TC-types require a collar for mounting.

## 11DU/11EU Dimensions

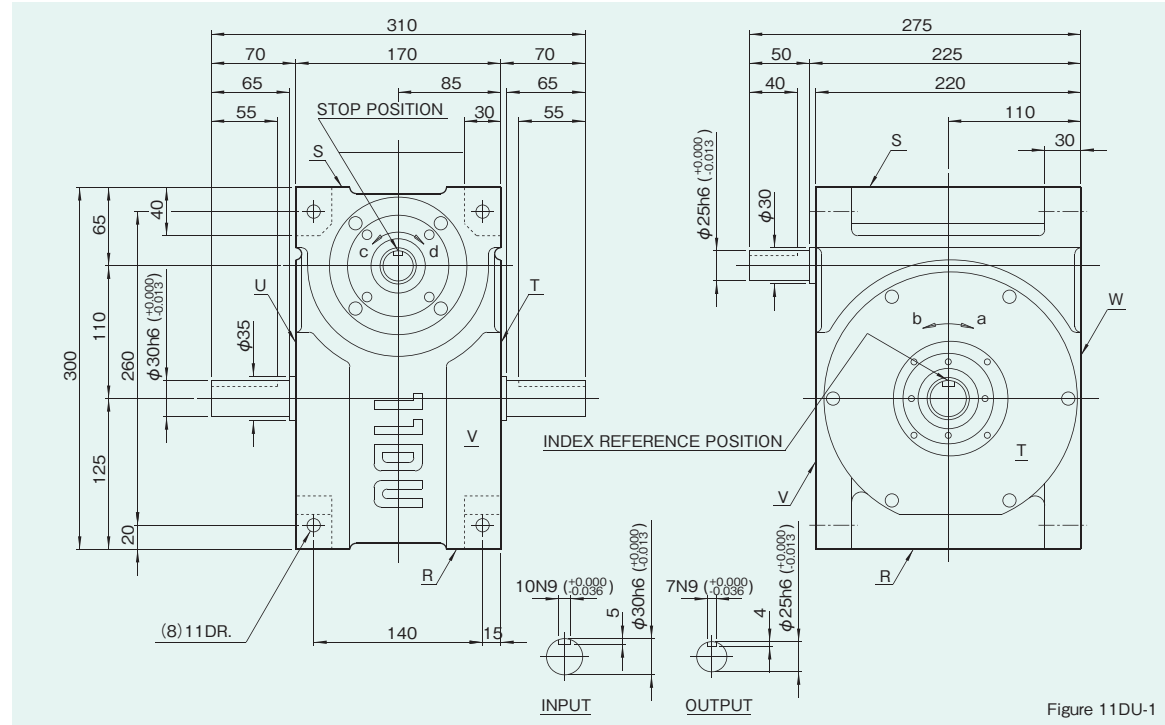
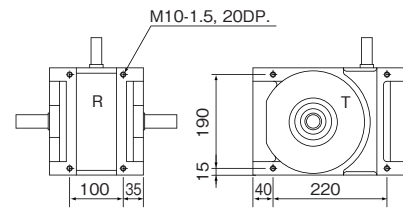

Figure 11DU-1

### Mounting hole locations

Figure 11DU-2



Dimensions of R,S,T, and U surface

### Locations of oil plug, etc., and oil capacity

Figure 11DU-3

Mounting position	1	2	3	4	5	6
Location						
Oil capacity(ℓ)	2.2	2.0	2.4	2.4	1.7	1.8

### Precautions

- Case of mounting position 5 and 6, S surface has 3holes.

### Precautions

- Each point indicated in the mounting positions shown in Figure 11DU-3 represents (starting at top) the oil plug (PT1/2), oil level (VA), and drain (PT1/2).
- The mounting positions correspond to code i for the indexing, oscillating, and roller drives.
- The oil levels indicated in Figure 11DU-3 are given in general figures and will differ according to the profile of the cam and the number of cam followers.

### Specifications

Table 11DU-1

Item	Symbol	Unit	Value	Item	Symbol	Unit	Value	Item	Symbol	Unit	Value
Output allowable axial load	P <sub>1</sub>	N	1960	Input allowable axial load	P <sub>4</sub>	N	2940	Indexing accuracy (1 DWELL)		sec	±45
Output allowable radial load	P <sub>2</sub>	N	1764	Input maximum repetitious bending force	P <sub>5</sub>	N	2548				
Output static torque	T <sub>s</sub>	N·m	Refer to Torque Capacity Table	Input maximum repetitious allowable torque	P <sub>6</sub>	N·m	735				
Output torsional rigidity	K <sub>1</sub>	N·m/rad	1.67×10 <sup>4</sup>	Input torsional rigidity	K <sub>2</sub>	N·m/rad	2.55×10 <sup>4</sup>				
Output inertia	J <sub>0</sub>	kg·m <sup>2</sup>	7.25×10 <sup>-4</sup>	Input inertia	J <sub>1</sub>	kg·m <sup>2</sup>	5.5×10 <sup>-2</sup>	Repetitive accuracy		sec	20
Output allowable bending moment	P <sub>3</sub>	N·m	40.2					Product weight		kg	65
								Housing color		Gray	

Note : Input inertia : J is calculated in dwell.

(1N=0.102kgf)

## Mounted accessories

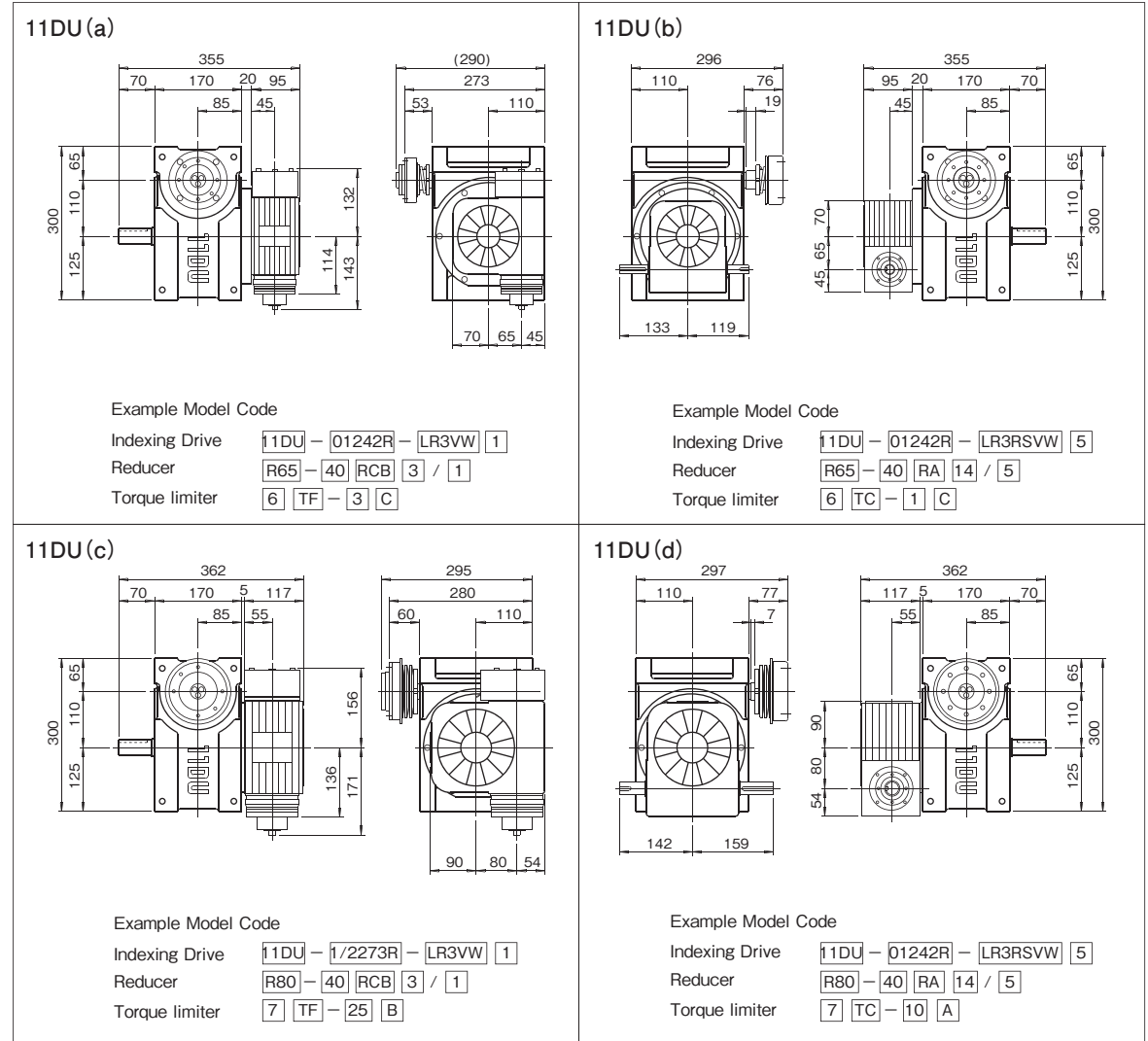

### Precaution

- Models 11DU and 11EU can be equipped with reducers R65 and R80.
- The reducer can be mounted in 16 different positions as shown on page of Reducer.
- Models 11DU, 11EU can be equipped with torque limiters 6TF, 7TF, 6TC and 7TC.
- Torque limiter TC-types require a collar for mounting.

## 14DU/14EU Dimensions

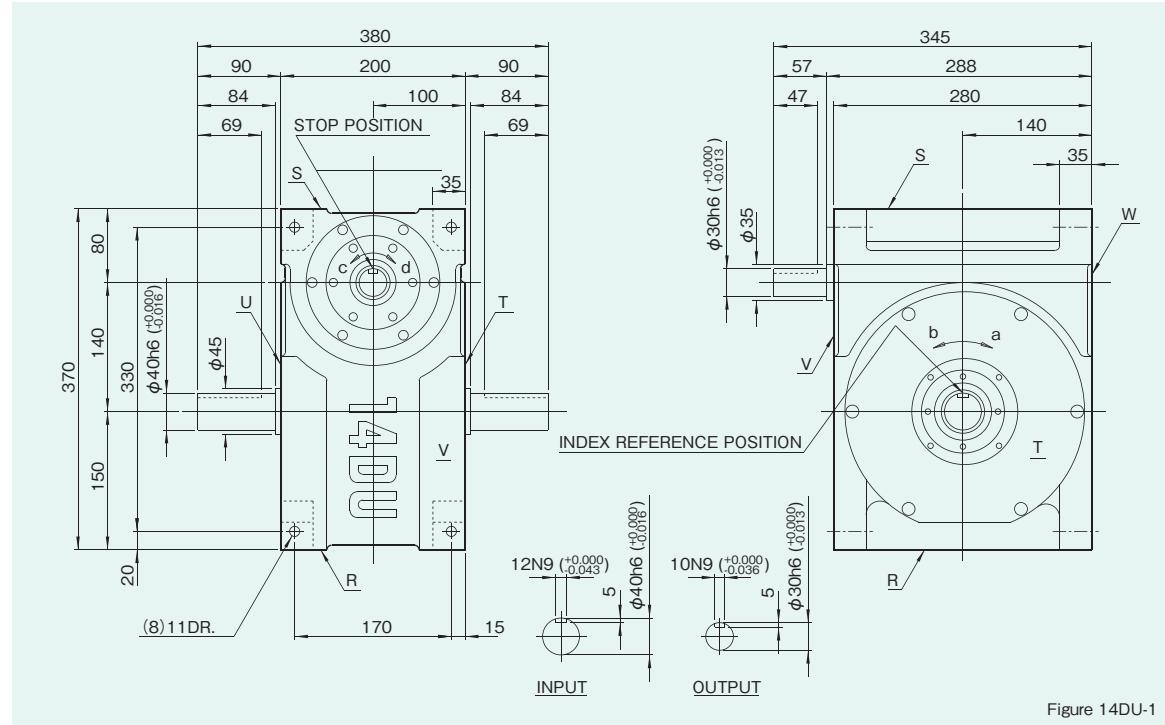
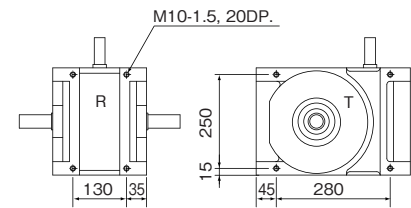

Figure 14DU-1

### Mounting hole locations

Figure 14DU-2



Dimensions of R,S,T, and U surface

### Locations of oil plug, etc., and oil capacity

Figure 14DU-3

Mounting position	1	2	3	4	5	6
Location						
Oil capacity (ℓ)	3.8	3.5	4	4	3	3.8

### Precautions

- Each point indicated in the mounting positions shown in Figure 14DU-3 represents (starting at top) the oil plug (PT1/2), oil level (VA), and drain (PT1/2).
- The mounting positions correspond to code i for the indexing, oscillating, and roller drives.
- The oil levels indicated in Figure 14DU-3 are given in general figures and will differ according to the profile of the cam and the number of cam followers.

### Specifications

Table 14DU-1

Item	Symbol	Unit	Value	Item	Symbol	Unit	Value	Item	Symbol	Unit	Value
Output allowable axial load	P <sub>1</sub>	N	2254	Input allowable axial load	P <sub>4</sub>	N	3136	Indexing accuracy (1 DWELL)		sec	±30
Output allowable radial load	P <sub>2</sub>	N	2646	Input maximum repetitious bending force	P <sub>5</sub>	N	3822				
Output static torque	T <sub>s</sub>	N·m	Refer to Torque Capacity Table	Input maximum repetitious allowable torque	P <sub>6</sub>	N·m	735				
Output torsional rigidity	K <sub>1</sub>	N·m/rad	3.72×10 <sup>4</sup>	Input torsional rigidity	K <sub>2</sub>	N·m/rad	1.08×10 <sup>5</sup>				
Output inertia	J <sub>0</sub>	kg·m <sup>2</sup>	1.33×10 <sup>-3</sup>	Input inertia	J <sub>1</sub>	kg·m <sup>2</sup>	0.173	Repetitive accuracy		sec	15
Output allowable bending moment	P <sub>3</sub>	N·m	63.7					Product weight		kg	103
								Housing color		Gray	

Note : Input inertia : J is calculated in dwell.

(1N=0.102kgf)

## Mounted accessories

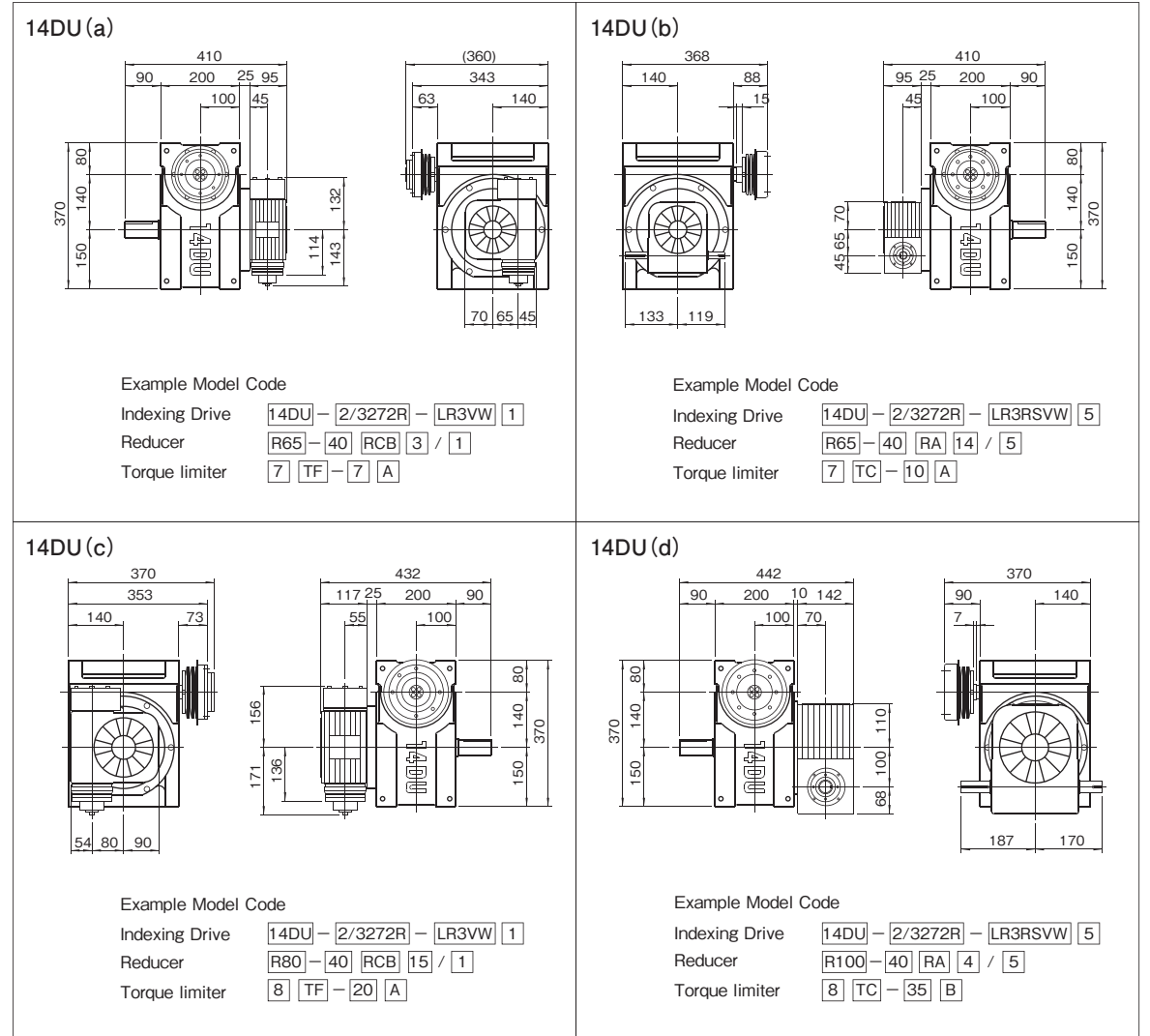

### Precaution

- Models 14DU and 14EU can be equipped with reducers R65, R80 and R100.
- The reducer can be mounted in 16 different positions as shown on page of Reducer.
- Models 14DU, 14EU can be equipped with torque limiters 7TF, 7TC, 8TF, and 8TC.
- Torque limiter TF-types require a collar for mounting.
- Torque limiter TC-types require a collar for mounting.

20DU/20EU Dimensions

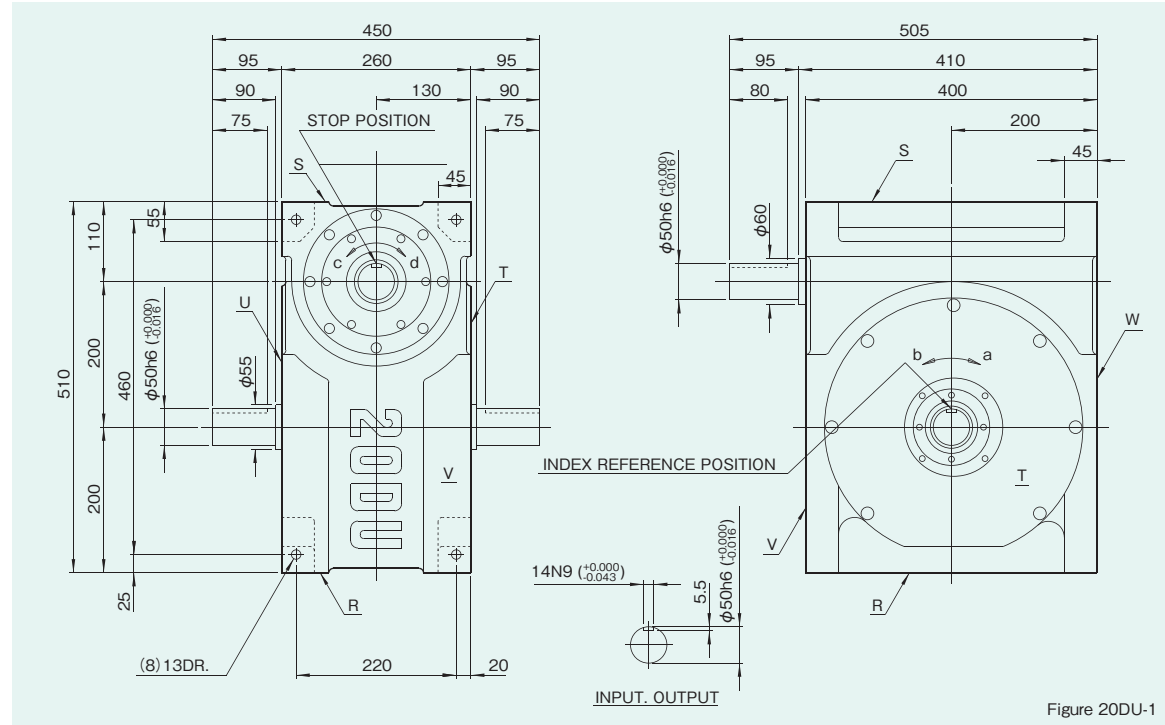
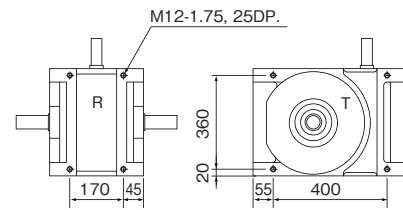

Figure 20DU-1

Mounting hole locations Figure 20DU-2



Dimensions of R,S,T, and U surface

Locations of oil plug, etc., and oil capacity Figure 20DU-3

Mounting position	1	2	3	4	5	6
Location						
Oil capacity(ℓ)	10	9	12	12	8	10

Precautions

- Each point indicated in the mounting positions shown in Figure 20DU-3 represents (starting at top) the oil plug (PT3/4), oil level (VB), and drain (PT3/4).
- The mounting positions correspond to code i for the indexing, oscillating, and roller drives.
- The oil levels indicated in Figure 20DU-3 are given in general figures and will differ according to the profile of the cam and the number of cam followers.

Specifications

Table 20DU-1

Item	Symbol	Unit	Value	Item	Symbol	Unit	Value	Item	Symbol	Unit	Value
Output allowable axial load	P <sub>1</sub>	N	6370	Input allowable axial load	P <sub>4</sub>	N	4900	Indexing accuracy (1 DWELL)		sec	±30
Output allowable radial load	P <sub>2</sub>	N	9506	Input maximum repetitious bending force	P <sub>5</sub>	N	6860				
Output static torque	T <sub>s</sub>	N·m	Refer to Torque Capacity Table	Input maximum repetitious allowable torque	P <sub>6</sub>	N·m	1372				
Output torsional rigidity	K <sub>1</sub>	N·m/rad	1.47×10 <sup>5</sup>	Input torsional rigidity	K <sub>2</sub>	N·m/rad	2.65×10 <sup>5</sup>				
Output inertia	J <sub>0</sub>	kg·m <sup>2</sup>	1.38×10 <sup>-2</sup>	Input inertia	J <sub>1</sub>	kg·m <sup>2</sup>	0.345	Repetitive accuracy		sec	15
Output allowable bending moment	P <sub>3</sub>	N·m	313.6					Product weight		kg	300
								Housing color		Gray	

Note : Input inertia : J is calculated in dwell.

(1N=0.102kgf)

Mounted accessories

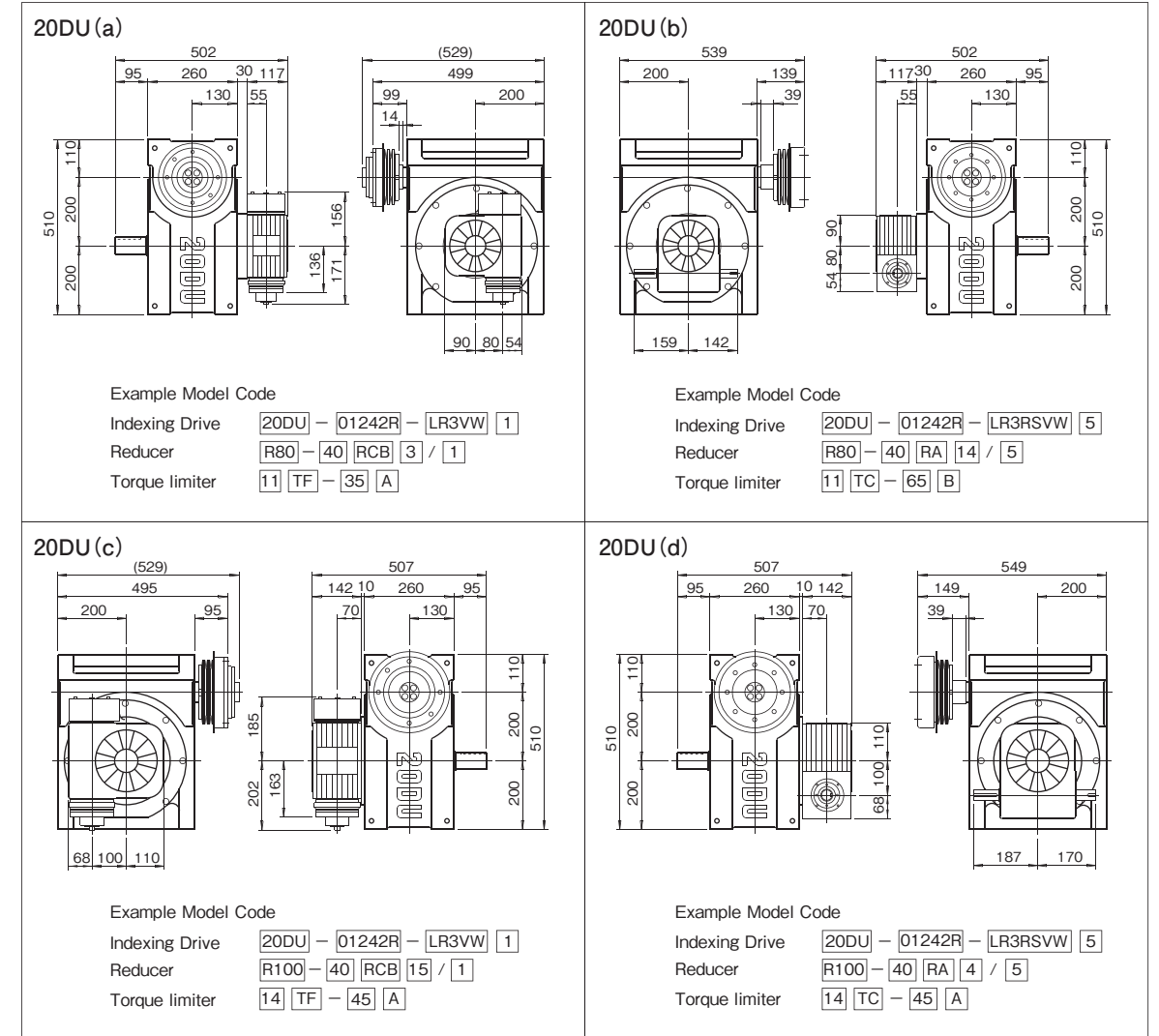

Precaution

- Models 20DU and 20EU can be equipped with reducers R80 and R100.
- The reducer can be mounted in 16 different positions as shown on page of Reducer.
- Models 20DU, 20EU can be equipped with torque limiters 11TF, 11TC, 14TF, and 14TC.
- Torque limiter 11TF-types require a collar for mounting.
- Torque limiter TC-types require a collar for mounting.