

TORQUE LIMITERS

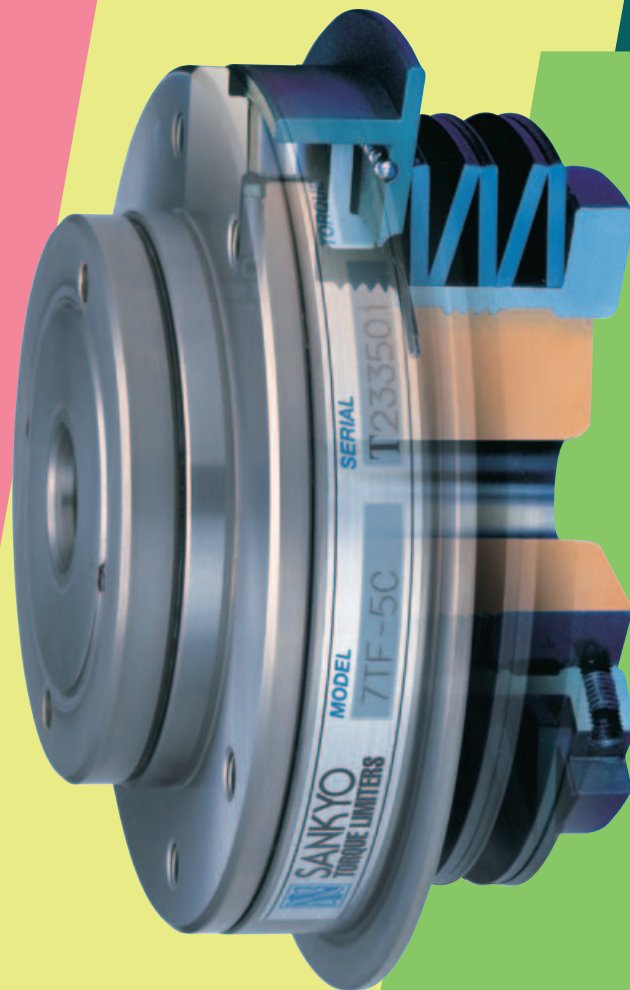

- FLANGE TYPE
- COUPLING TYPE

Reliable Hi-Quality Overload Protector

DESCRIPTION

The Sankyo torque limiter is a safety device designed to protect mechanical equipment from overloads. When an excessive torque load occurs, the torque limiter trips or, shuts off the transmission of torque to protect the machine. The protection provided could mean avoiding personal injury or secondary disasters.

Sankyo's design follows the separation principle, commonly regarded as the most reliable principle available. The torque tripping mechanism is based on the mechanical transmission of torque formed by a ball and ball pocket, or a roller and roller pocket combination. This mechanism ensures accurate torque shut-off and easy trip-point adjustment without degrading performance of the equipment to which it is installed.

The cam used in an automated machine is undoubtedly the core component of that machine. For that reason, the following conditions must be met:

- Easy return to origin after an overload (one-point setting position)
- Accurate torque transmission
- No backlash and rigidity
- Ability to detect an overload.

Sankyo Torque Limiters meet these requirements which explains its reputation as the most reliable safety device available.

TORQUE LIMITERS					
	Separation (mechanical)		Slippage	Destructive	Electromagnetic
Mechanism	Ball and ball pocket Roller and roller pocket	Cam mechanism	Friction disk	Shear pin shear plate	Electromagnetic (tooth clutch or friction clutch)
Trip-point accuracy	Excellent	Excellent	Fair	Good	Good or Fair
Ease of trip-point adjustment	Easy	Good	Easy	Difficult	Good
Overload detection ability	Yes	Yes	Yes	No	Yes
Ease of re-establishing connection after tripping	Easy	Easy	Easy	Difficult	Easy
Reset point accuracy	Excellent	Good	Poor	Poor	Conditions vary
One-point setting position	Yes	Yes	No	No	Conditions vary
Suitability to harsh operating conditions	High	High	Low	High	Good
Maintenance	Very easy	Easy	Difficult	Difficult	Easy

TF Series [Flange Type]



Sankyo's TF Series features a low-profile design and a flange for directly mounting tables, gears, sprockets, etc. The overload protection is effective only in the radial direction. Torque transmission in the normal state is accurate with no backlash or motion loss.

Features

- Roller & roller pocket method.
- Eliminates backlash in all directions yet maintains strong rigidity.
- Excellent torque transmission, working characteristics and handling.
- One-point setting feature.
- Easy-to-adjust torque setting.
- Clean Model design is available options.



Clean model
[7TF-C2]

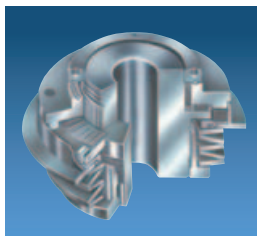

Construction of TF series

TC Series [Coupling Type]

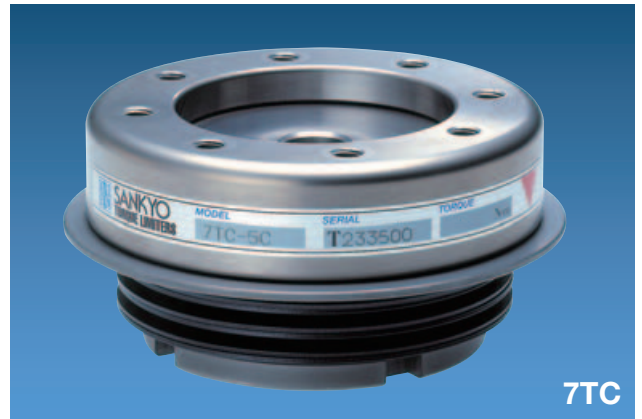

Sankyo's TC Series provides overload protection between two shafts. The protection is effective only in the radial direction. Preloaded ball bearings ensure rigid torque transmission. Another feature of the TC series is its inherent ability to absorb misalignment between the two shafts.

Features

- Ball & ball pocket mechanism for longer life.
- Coupling function.
- One-point setting feature.
- Easy-to-adjust torque setting.
- Detects overloads.
- Clean Model design is available options.



Clean model
[7TC-C2]



Construction of TC series

4TF~5TF

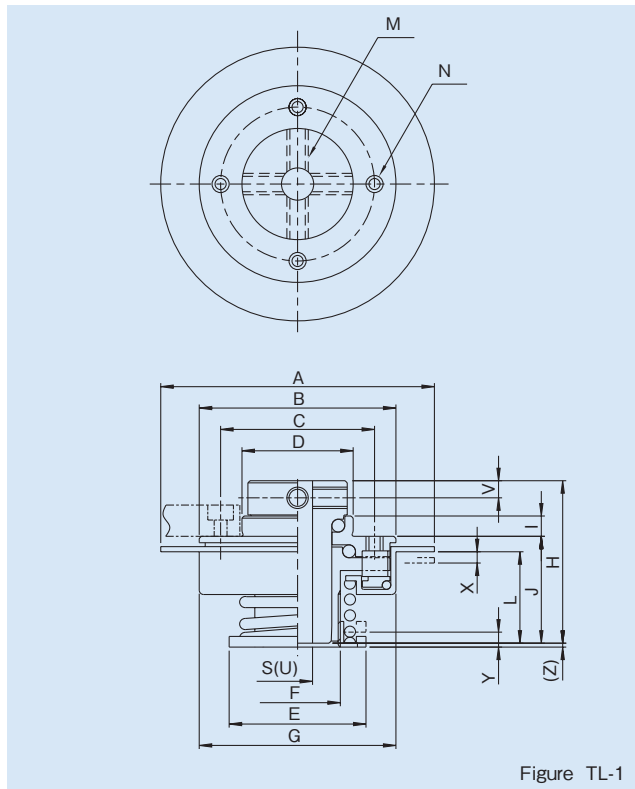

6~18TF

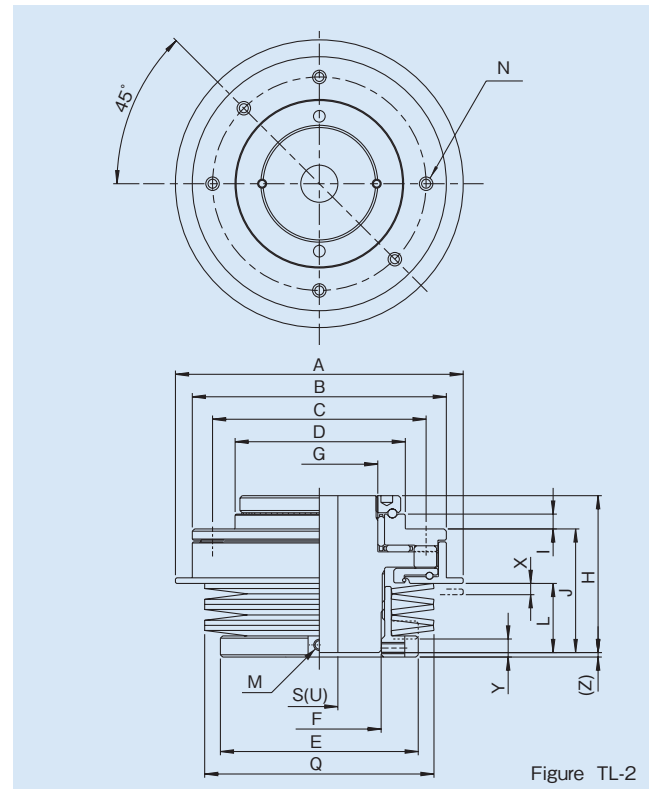

Table of TF series Dimension

[Unit : mm] Table TL-1

Model	A	B	C	D	E	F	G	H	I	J	L	M	N	Q	S	U	V	X	Ymax	(Z)
4TF-007C											21.2							1.1	2.2	0.7
4TF-010C	64	46	PCD	26	32	M20	46	38	4.7	25	21.4	4-M5	4-M4		7	12	4	1.3	2.4	0.5
4TF-030C			36	h7		P1					21.2	P0.8	P0.7					1.1	2.5	0.7
4TF-045C											21.4		DP.4.7					1.3	3.3	0.5
5TF-030C											29.0							0.9	5.6	1.3
5TF-060C	82	63	PCD	35	45	M30	63	50	4.7	34	29.5	4-M6	4-M4		9	20	6	1.4	5.0	0.8
5TF-100C			50	h7		P1.5					29.0	P1	P0.7					0.9	7.5	1.3
5TF-180C											29.5		DP.5.7					1.4	6.4	0.8
6TF-07C											25.0							1.3	9.0	3.9
6TF-1C	88	88	PCD	60	58	M40	M40	60	5	48	25.5	2-M5	6-M6		12.5	30		2.0	7.6	3.2
6TF-3C			75	h7		P1.5	P1.5				25.0	P0.8	P1					1.3	9.5	3.9
6TF-5C											25.5		DP.7					2.0	9.8	3.2
7TF-7A											30.0							1.6	5.3	1.7
7TF-12A	128	113	PCD	75	88	55	M52	70	6.6	55	31.0	2-M5	6-M6		102	16.5	40	2.5	4.9	0.9
7TF-25B			95	h7		P1.5					30.0	P0.8	P1					1.6	6.2	1.4
7TF-40B											31.0		DP.9					2.5	6.2	0.6
8TF-12A											37.5							1.6	6.2	0
8TF-20A	164	138	PCD	100	108	75	M72	82	7.6	65	38.5	2-M5	6-M8		130	16.5	52	2.5	6.2	-0.8
8TF-40B			120	h7		P1.5					37.5	P0.8	P1.25					1.6	7.5	-0.7
8TF-60B											38.5		DP.11					2.5	7.0	-1.5
11TF-25A											42.0							2.0	7.3	2.0
11TF-35A	198	170	PCD	120	134	96	M90	95	9.6	75	43.0	2-M5	6-M10		160	27	68	3.0	5.0	1.0
11TF-85B			148	h7		P1.5					42.0	P0.8	P1.5					2.0	7.7	-0.5
11TF-120B											43.0		DP.13					3.0	7.4	-1.5
14TF-30A											43.5							2.2	6.4	4.2
14TF-45A	236	206	PCD	150	158	120	M120	105	10.4	85	44.5	2-M6	6-M12		186	27	90	3.5	5.5	2.9
14TF-120B			180	h7		P1.5					43.5	P0.75	P1.75					2.2	9.0	3.2
14TF-180B											44.5		DP.15					3.5	8.6	1.9
18TF-130A											59.0							3.3	10.7	5.0
18TF-180A	280	252	PCD	180	220	165	M140	135	12	110	60.5	2-M6	6-M16		236	50	110	5.0	7.7	3.3
18TF-300B			215	h7		P2					59.0	P0.75	P2					3.3	8.8	5.2
18TF-500B											60.5		DP.20					5.0	7.7	3.5

*Specifications and dimensions are subject to change without notice. Always double check before ordering.

4TC~5TC

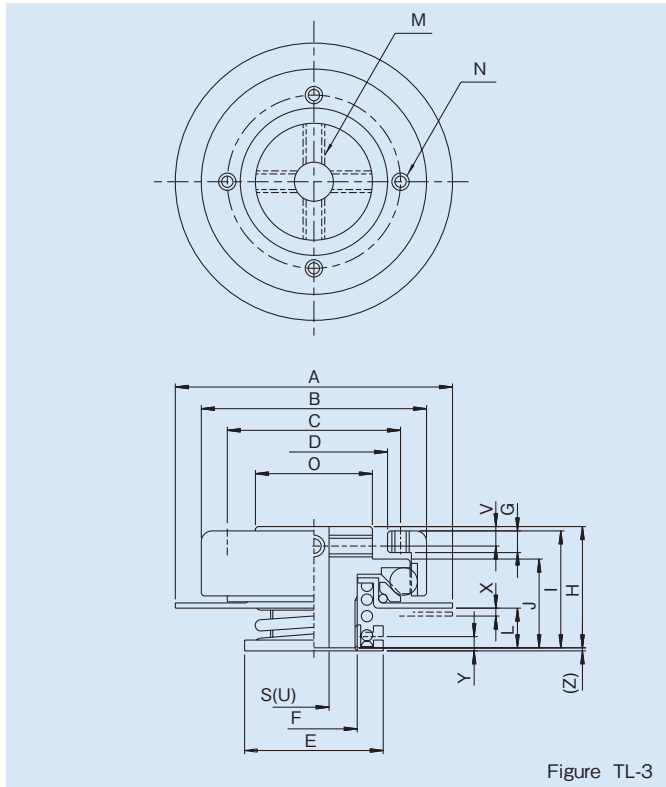

Figure TL-3

6~18TC

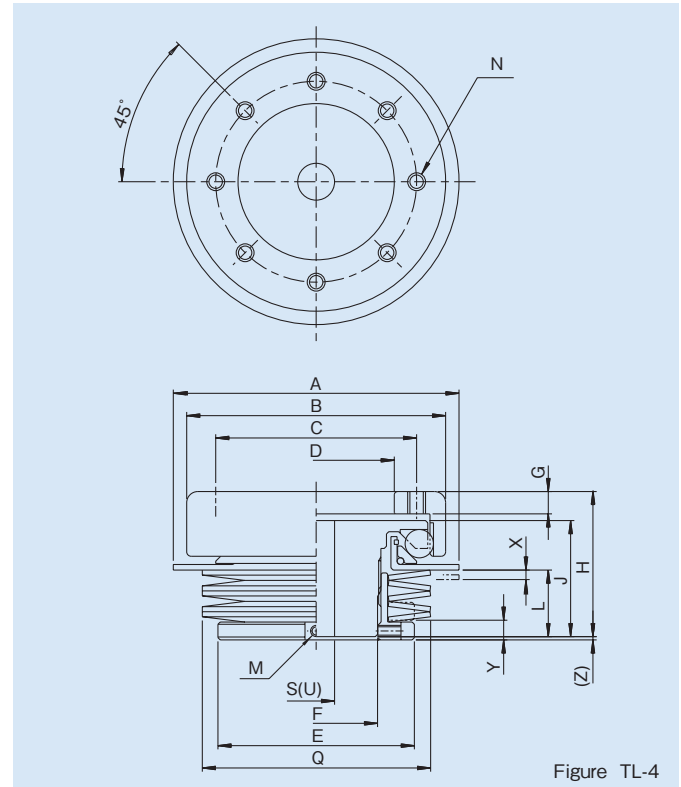

Figure TL-4

Table of TC series Dimension

(Unit : mm) Table TL-2

Model	A	B	C	D	E	F	G	H	I	J	L	M	N	Q	S	U	O	V	X	Ymax	(Z)
4TC-007C											7.6								0.7	2.7	0.6
4TC-010C	64	52	PCD	34	32	M20	5	28	27	20.5	8.0	4-M5	4-M4		7	15	27	4.5	1.1	3.0	0.2
4TC-030C			40	H7		P1					7.6	P0.8	P0.7						0.7	3.3	0.6
4TC-045C											8.0		DP.5						1.1	4.0	0.2
5TC-030C											13.1								0.6	5.4	0.3
5TC-060C	82	71	PCD	46	45	M30	7	40	39	30	13.7	4-M6	4-M4		9	22	36	5.5	1.2	6.5	-0.3
5TC-100C			55	H7		P1.5					13.1	P1	P0.7						0.6	7.6	0.3
5TC-180C											13.7		DP.7						1.2	8.0	-0.3
6TC-06C											18.5								1.4	8.7	3.2
6TC-1C	93	95	PCD	50	58	M40	9	52		40	19.0	2-M5	8-M6		12.5	30			2.2	5.7	2.8
6TC-3C			70	H7		P1.5					18.5	P0.8	P1						1.4	10.0	3.2
6TC-5C											19.0		DP.9						2.2	9.6	2.8
7TC-6A											30.0								1.6	6.4	2.0
7TC-10A	128	116	PCD	70	88	55	10	65		52	31.0	2-M5	8-M8		16.5	40			2.6	7.1	0.9
7TC-20B			90	H7							30.0	P0.8	P1.25						1.6	6.4	1.7
7TC-35B											31.0		DP.10						2.6	6.2	0.6
8TC-12A											35.0								1.7	10.8	2.5
8TC-15A	164	142	PCD	90	108	75	12	75		60	36.0	2-M5	8-M8		130	16.5	52		2.7	5.9	1.6
8TC-35B			110	H7							35.0	P0.8	P1.25						1.7	6.9	1.8
8TC-45B											36.0		DP.12						2.7	5.7	0.9
11TC-20A											41.5								2.0	10.8	2.4
11TC-35A	198	176	PCD	110	134	96	16	90		70	43.0	2-M5	8-M10		160	27	68		3.2	11.2	1.0
11TC-65B			130	H7							41.5	P0.8	P1.5						2.0	7.4	-0.1
11TC-100B											43.0		DP.16						3.2	6.7	-1.5
14TC-30A											44.0								2.1	7.5	4.5
14TC-45A	236	208	PCD	130	158	120	16	100		80	44.0	2-M6	8-M12		186	27	90		3.7	6.0	4.5
14TC-130B			160	H7							44.0	P0.75	P1.75						2.1	10.0	3.5
14TC-200B											44.0		DP.16						3.7	10.2	3.5
18TC-160A											59.0								3.7	12.5	4.8
18TC-250A	285	285	PCD	170	220	170	18	130		108	59.0	2-M6	8-M16		236	50	130		6.2	8.3	5.0
18TC-380B			220	H7							59.0	P0.75	P2						3.7	8.0	5.0
18TC-500B											59.0		DP.18						6.2	6.5	5.2

*Specifications and dimensions are subject to change without notice. Always double check before ordering.

SPECIFICATIONS

Precautions

- M : The diameter and pitch of the set-screw inside the torque adjusting nut.
- N : The Depth of mounting taps(Use in conjunction with N value)
- S : Pre-drilled starter hole size
- U : Maximum drilling dimensions (implies that starting hole S can be drilled to maximum dimensions U.)
- X : When an overload occurs, the overload detection panel moves X mm.(Refer to Figure TL-6)
- Ymax : Maximum tightening length
- (Z) : This dimension indicates the height when the spring is free and should be referred to when calculating tripping torque.
- T : Adjusting range for tripping torque
- a : Maximum allowable radial load
- b : Maximum allowable thrust load
- c : Maximum allowable bending moment
- δ : Maximum allowable angle of deviation error
- α : Maximum allowable clearance error
- ϵ : Maximum allowable parallelism error
- Nmax : Maximum allowable rotating speed
- J : Inertia moment of torque limiter
- W : Weight

- Note 1. The amount of clearance error α is the amount of allowable axial movement based on the assembly dimensions of H.
- Note 2. Parallelism error ϵ indicates the maximum amount of absorption that occurs at the torque transmitting ball of the torque limiter.
- Note 3. Please consult Sankyo for use at speeds that exceed the value of Nmax.

Shaft mounting flange(option)

Shaft mounting flange can be premachined as shown in the table below.

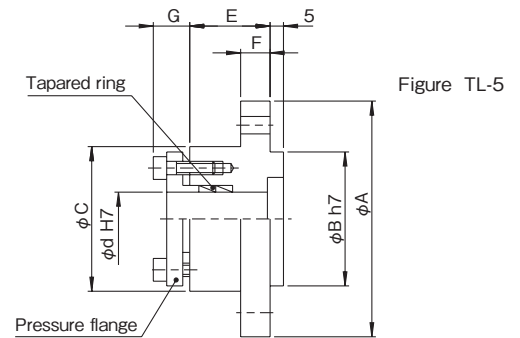

Dimensions

Table TL-5

	A	B	C	D	E	F	G
6TC	88	50	54	16~25	30	11	(13.6)
7TC	108	70	70	20~40	35	15	(16)
8TC	126	90	90	30~45	40	15	(20)
11TC	152	110	108	40~60	40	15	(26)
14TC	185	130	135	50~65	55	15	(33)

*Please consult Sankyo for use of 4TC, 5TC and 18TC.

Table of TF series specifications

Table TL-3

Model	T (N·m)	a (N)	b (N)	c (N·m)	Nmax (rpm)	J (kg·m ²)	W (kg)
4TF-007C	0.3~0.7	69	392	3.4	2000	0.05 ×10 ⁻³	0.24
4TF-010C	0.4~1.0						
4TF-030C	1.0~3.0						
4TF-045C	1.5~4.5						
5TF-030C	0.8~3.0	108	569	6.9	1600	0.24 ×10 ⁻³	0.50
5TF-060C	1.5~6.0						
5TF-100C	2.0~10.0						
5TF-180C	4.0~18.0						
6TF-07C	2~7	3822	7938	118	800	1.3 ×10 ⁻³	1.5
6TF-1C	3~10						
6TF-3C	10~30						
6TF-5C	15~50						
7TF-7A	22~70	7154	10780	196	600	4.8 ×10 ⁻³	3.4
7TF-12A	40~120						
7TF-25B	80~250						
7TF-40B	120~400						
8TF-12A	50~120	10290	14700	372	400	0.015	6.2
8TF-20A	70~200						
8TF-40B	120~400						
8TF-60B	200~600						
11TF-25A	80~250	14700	22050	666	300	0.035	11.4
11TF-35A	120~350						
11TF-85B	220~850						
11TF-120B	350~1200						
14TF-30A	110~300	23520	28420	1019	250	0.085	20
14TF-45A	150~450						
14TF-120B	420~1200						
14TF-180B	600~1800						
18TF-130A	400~1300	30184	35280	1441	180	0.3	42
18TF-180A	800~1800						
18TF-300B	1500~3000						
18TF-500B	3000~5000						

Table of TC series specifications

Table TL-4

Model	T (N·m)	δ (deg)	α (mm)	ϵ (mm)	Nmax (rpm)	J (kg·m ²)	W (kg)
4TC-007C	0.3~0.7	1	±1.0	0.05	2000	0.09 ×10 ⁻³	0.25
4TC-010C	0.4~1.0						
4TC-030C	1.0~3.0						
4TC-045C	1.5~4.5						
5TC-030C	0.8~3.0	1	±1.0	0.05	1600	0.4 ×10 ⁻³	0.68
5TC-060C	1.5~6.0						
5TC-100C	2.0~10.0						
5TC-180C	4.0~18.0						
6TC-06C	2~6	1.5	±1.5	0.05	1000	1.7 ×10 ⁻³	1.5
6TC-1C	3~10						
6TC-3C	8~30						
6TC-5C	15~50						
7TC-6A	20~60	1.2	±1.8	0.1	700	5.8 ×10 ⁻³	3.2
7TC-10A	30~100						
7TC-20B	60~200						
7TC-35B	100~350						
8TC-12A	40~120	1.2	±2	0.1	500	0.014	5.3
8TC-15A	60~150						
8TC-35B	100~350						
8TC-45B	120~450						
11TC-20A	70~200	1	±2.5	0.1	400	0.035	10.8
11TC-35A	100~350						
11TC-65B	200~650						
11TC-100B	300~1000						
14TC-30A	100~300	0.7	±3.5	0.1	300	0.093	20
14TC-45A	150~450						
14TC-130B	500~1300						
14TC-200B	800~2000						
18TC-160A	700~1600	0.5	±3.5	0.1	200	0.4	45
18TC-250A	1000~2500						
18TC-380B	1600~3800						
18TC-500B	3000~5000						

1N·m≒0.102kgf·m

MODEL SELECTION

Torque limiter selection

Torque limiters are mechanical overload clutches used to prevent overloading by automatically disengaging in the event of excessive torque.

They should be mounted on the nearest place of the final output number most likely to cause trouble.

It is necessary to choose the proper model/size torque limiter which best fits the application (i.e. purpose, configuration) to effectively prevent overloads from affecting the drive train.

Calculation procedure

(1)Type selection

a)TF series : for direct mounting of table, arm, gear or sprocket

b)TC series : for engagement of two shafts

(2)Required torque for normal operation

(a)When mounting torque limiter onto an output shaft of an indexing device, the total torque for the output shaft(T_t), should be calculated as the required torque.

(b)When mounting torque limiter onto the input shaft of an indexing device, cam shaft torque(T_c) should be calculated as the required torque.

(3)Tripping torque

Service factor(F) multiplied by the required torque(T_t , T_c) is the tripping torque(T)

Service factor(F)

Table TL-6

Shaft speed(rpm)	to 40	over 40 to 200	over 200
Indexing device output shaft	1.5~2	1.75~2.2	2~3
Indexing device input shaft	1.4~1.75	1.6~2	1.75~2.5
Transmission output shaft	1.5~2	1.75~2.2	2~3
Reducer output shaft	1.4~1.75	1.6~2	1.75~2.5

(4)Size selection

(a)TF series

In consideration of above-calculated radial load, thrust load and bending moment, select a size with a tripping torque(T) rating within the range of adjustment(ref.(T) of dimension table).

(b)TC series

In consideration of shaft diameter and offset of parallelism and angle, select the size for which tripping torque(T) is within the range of adjustment (ref (T) of dimension table)

(5)Etc.

For proper selection, confirm whether the maximum tripping torque(T) exceeds the static-rated torque(T_s) of an indexing drive.

Model code

Model code example



•Pre-machined shaft holes

When ordering, specify the shape of the intended shaft hole. Otherwise, the torque limiter will be shipped with only a pre-drilled starter hole.

a Torque limiter size	b Model	c Maximum tripping torque	d Type of spring
7	TF TF series	40 $T_{max} 400N \cdot m(40kgf \cdot m)$	B Heavy-duty bellville springs
Indicates the size of the torque limiter	Indicates the type of torque limiter TF TF series TC TC series	Indicates the maximum tripping torque	A Light-duty Bellville springs B Heavy-duty Bellville springs C Coil springs

*For further information of shaft hole, please contact sankyo by e-mail or visit our website.

Appendix

Using a Overload detection switch

When an overload occurs, the overload detection panel will move X mm (as documented in our brochure). The customer can use this feature to detect the overload with a sensor which should be tied into the drive control system.

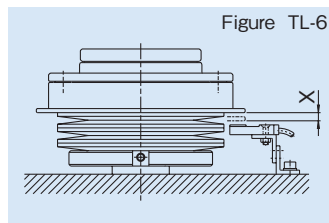

Figure TL-6

(1)Proximity switches

Proximity switches are ideal for detecting the torque limiter overload detection panel because they function on a non-contact principle. Proximity switches are available in low-profile designs (see table below) making them suitable for tight locations.

(2)Micro switches

Micro switches function on contact and should therefore be used for low-speed applications. When selecting a micro switch, pay attention to the operating distance of the switch. Also the switch should be mounted so that it touches the panel when an overload occurs, not in normal operating condition.

CHARACTERISTICS

Table TL-7

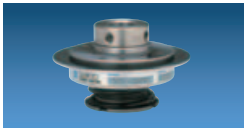
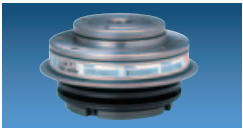
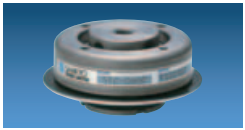
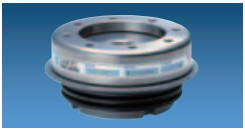
	Miniature Flange-Type (4-5TF)	Flange-Type (6-18TF)	Miniature Coupling-Type (4-5TC)	Coupling-Type (6-18TC)	
Model					
Function	Size	2 Model 8 Kinds	6 Model 24 Kinds	2 Model 8 Kinds	6 Model 24 Kinds
	Range of Tripping Torque	0.3-18N·m	2-5000N·m	0.3-18N·m	2-5000N·m
	Torque Tripping Mechanism	Roller and/or Roller Pocket	Roller and/or Roller Pocket	Ball and/or Ball Pocket	Ball and/or Ball Pocket
	Auto-resetting	Yes	Yes	Yes	Yes
	Torque Adjustment Method	Change the pressure force of spring by turning the nut	Change the pressure force of spring by turning the nut	Change the pressure force of spring by turning the nut	Change the pressure force of spring by turning the nut
	Single Position Setting	Yes	Yes	Yes	Yes
	Coupling Function	No	No	Yes	Yes
	Overload Detection	Yes	Yes	Yes	Yes
	Lubrication	Grease	Grease	Grease	Grease
	Clean model design	Yes	Yes	Yes	Yes
Load	Torsional Modulus of Elasticity	Fair	Excellent	Fair	Good
	Radial Load	Good	Excellent	—	—
	Thrust Load	Good	Excellent	—	—
	Bending Moment	Good	Excellent	—	—
	Permissible Revolutions per Minute	Max. 1600-2000r.p.m.	Max. 180-800r.p.m.	Max. 1600-2000r.p.m.	Max. 200-1000r.p.m.
Accuracy	Lost Motion on the Rotating Direction	1-2 min.	30 sec.	1-2 min.	30 sec.
	Resetting Accuracy	±30 sec.	±15 sec.	±30 sec.	±15 sec.
	Accuracy of Tripping Torque	±15%	±10%	±15%	±10%

Applications of TF series

TF Mounted on output shaft for mounting a table

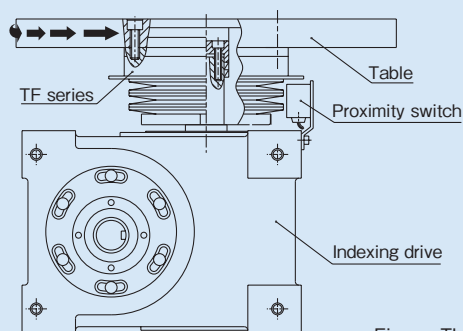

Figure TL-7

TF Mounted on a rotating shaft for driving a cam, gear, or sprocket.

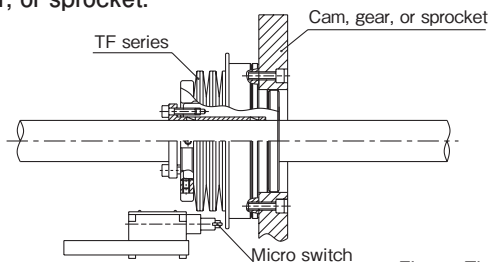

Figure TL-8

Applications of TC series

TC Used as coupling between index and conveyor drive shaft

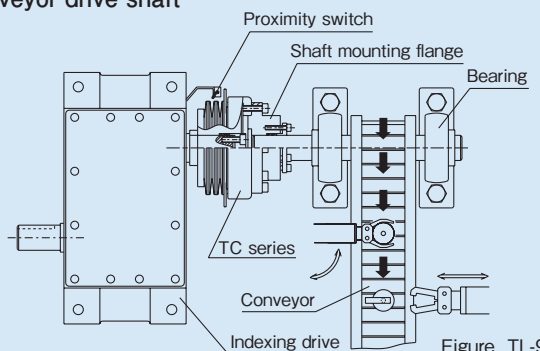

Figure TL-9

TC Used between two shafts

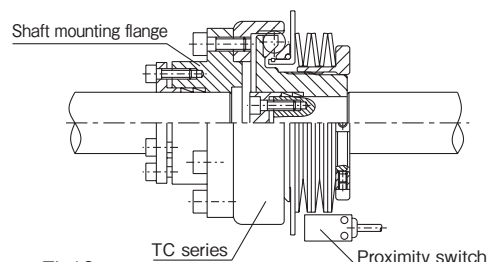
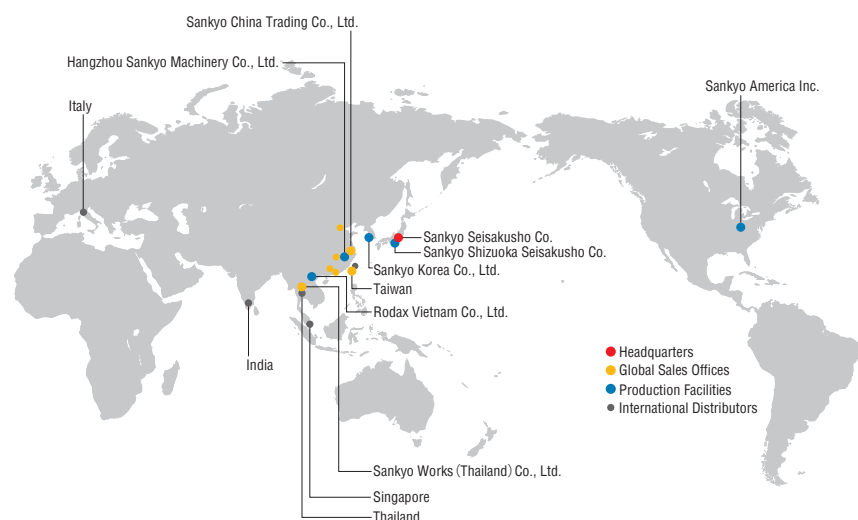

Figure TL-10

*Please consult Sankyo for the method of fastening.



Group Companies

Sankyo America Inc.
10655 State Route 47 Sidney, Ohio, 45365 U.S.A.
Phone: +1-(0)937-498-4901 Fax: +1-(0)937-498-9403
Email: sales@sankyoautomation.com

Sankyo Korea Co., Ltd.
1449-48 Seobu-ro, Gwonseon-gu, Suwon-si, Gyeonggi-do, 16643 Korea
Phone: +82-(0)31-895-5991 Fax: +82-(0)31-895-6607
Email: kr-sales@rollerdrive.com

Sankyo China Trading Co., Ltd.
[Shanghai Sales Office]
Room 1103, Block B, No.391 Guiping Road,
Shanghai 200233 China
Phone: +86-(0)21-5445-2813 Fax: +86-(0)21-5445-2340
Email: sales@sankyochina-trading.com

[Shenzhen Sales Office]
Unit 19, Tower B, Neo Building, No.6009 Shennan Avenue,
Futian District, Shenzhen China
Phone: +86-(0)755-8230-0270 Fax: +86-(0)755-8236-4605

[Tianjin Sales Office]
Room 1905, Pengzhanfeiwu Building A, Crossing Yale Road Yaolin Road,
Xiqing District, Tianjin 300380 China
Phone: +86-(0)22-2312-1005 Fax: +86-(0)22-2312-1007

[Guangzhou Sales Office]
Room 913, Xing Pu Building, No.12 Guan Hong Road,
Guangzhou Economic Development Zone, Huang Pu,
Guang Zhou 510670 China
Phone: +86-(0)20-8985-1846 Fax: +86-(0)20-8225-7346

[Wuhan Sales Office]
Room 2301, Taihe Square, No.134 Wusheng Road, Wuhan,
Hubei Province China
Phone: +86-(0)27-8568-5818 Fax: +86-(0)27-8568-2818

Hangzhou Sankyo Machinery Co., Ltd.
No.2518 Jiang Dong 2 Road, Hangzhou Jiang Dong Industrial Park,
Xiaoshan Zone, Hangzhou, Zhejiang, China
Phone: +86-(0)571-8283-3311 Fax: +86-(0)571-8283-1133

Rodax Vietnam Co., Ltd.
Plot No. M1, Thang Long Industrial Park II
Di Su, My Hao, Hung Yen, Viet Nam
Phone: +84-(0)221-3-589701 Fax: +84-(0)221-3-589708

Sankyo Works (Thailand) Co., Ltd.
9/31 Moo 5, Phaholyotin Road, Klongnueng,
Klong Luang, Patumthani 12120 Thailand
Phone: +66-(0)2-516-5355 Fax: +66-(0)2-068-0931
Email: sales@sankyo-works.co.th

Contact us

Mon–Fri AM8:30–12:00 PM13:00–17:30 UTC + 09:00 (JST) (Except public holidays and company holidays)

■ **Headquarters**
(International Sales Division) 3-37-3 Tabatashinmachi, Kita-ku, Tokyo, Japan 114-8538
Phone: +81-(0)3-3800-3330
Fax: +81-(0)3-3800-3380
Email: overseas@sankyo-seisakusho.co.jp
URL: <http://www.sankyo-seisakusho.co.jp>

■ **Taiwan Sales Office** No.21, Ln.152, Jianxing Rd., Sanhe Vil., Daya Dist., Taichung City 42876, Taiwan (R.O.C.)
Phone: +886-(0)4-2359-4048
Fax: +886-(0)4-2359-4720
Email: tw-sales@rollerdrive.com



<http://www.sankyo-seisakusho.co.jp>

For further information, questions, or inquiries,
please contact us by e-mail or visit our website.
Specifications and dimensions are subject to change without notice.
Consult Sankyo sales before ordering.

