

オイル栓、オイルレベル、ドレンの位置(オイル潤滑仕様の場合) Position of oil level and oil plug and drain (Case of oil lubrication)

視点 View from	取付姿勢 Mounting position	1		2		3		4		5		6			
		T	U	T	U	T	U	T	U	T	U	T	U		
S面 S surface side		A	オイル栓 Oil plug RC3/8	オイル栓 Oil plug RC3/8	ドレン Drain RC3/8	ドレン Drain RC3/8					オイル栓 Oil plug RC3/8	オイル栓 Oil plug RC3/8	ドレン Drain RC3/8	ドレン Drain RC3/8	
		A-1	92	92	92	92					92	92	92	92	
		A-2	51	51	51	51					51	51	51	51	
V面 V surface side		B											オイルレベル Oil level (W面に加工 W surface only)	オイルレベル Oil level (W面に加工 W surface only)	
		B-1											90	90	
		B-2											42	42	
R面 R surface side		C					オイルレベル Oil level	オイルレベル Oil level	オイルレベル Oil level	オイルレベル Oil level					
		C-1					32	32	88	88					
		C-2					40	40	40	40					
		D	ドレン Drain RC3/8	ドレン Drain RC3/8	オイル栓 Oil plug RC3/8	オイル栓 Oil plug RC3/8	ドレン Drain RC3/8	ドレン Drain RC3/8	ドレン Drain RC3/8	ドレン Drain RC3/8	ドレン Drain RC3/8	ドレン Drain RC3/8	ドレン Drain RC3/8	オイル栓 Oil plug RC3/8	オイル栓 Oil plug RC3/8
		D-1	32	32	32	32	88	88	32	32	32	32	32	32	
D-2	18	18	18	18	18	18	18	18	18	18	18	18	18		
U面 U surface side		E							オイル栓 Oil plug RC1/8	オイル栓 Oil plug RC1/8					
		E-1							48	48					
		E-2							120	120					
		F	オイルレベル Oil level		オイルレベル Oil level							オイルレベル Oil level			
		F-1	40		40							40			
F-2	80		80							80					
T面 T surface side		G					オイル栓 Oil plug RC1/8	オイル栓 Oil plug RC1/8							
		G-1					48	48							
		G-2					120	120							
		H	オイルレベル Oil level		オイルレベル Oil level							オイルレベル Oil level			
		H-1	40		40							40			
H-2	80		80							80					

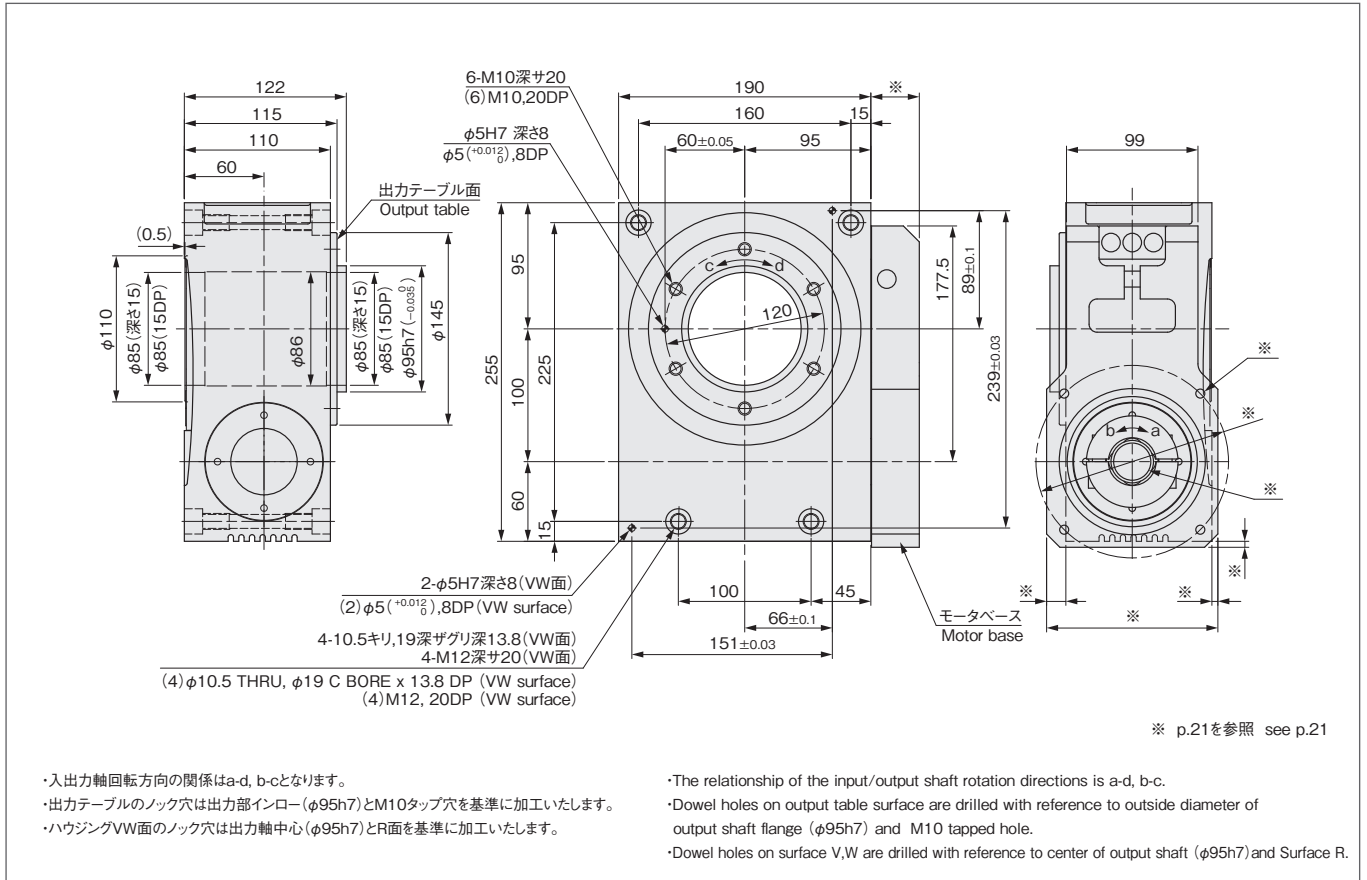

オイル栓、オイルレベル、ドレンの位置(オイル潤滑仕様の場合) Position of oil level and oil plug and drain (Case of oil lubrication)

視点 View from	取付姿勢 Mounting position	1		2		3		4		5		6		
View from	Servomotor position	T	U	T	U	T	U	T	U	T	U	T	U	
S面 S surface side		A	オイル栓 Oil plug RC1/2	オイル栓 Oil plug RC1/2	ドレン Drain RC1/2	ドレン Drain RC1/2	ドレン Drain RC1/2	ドレン Drain RC1/2	ドレン Drain RC1/2	ドレン Drain RC1/2	オイル栓 Oil plug RC1/2	オイル栓 Oil plug RC1/2	ドレン Drain RC1/2	ドレン Drain RC1/2
		A-1	142	142	142	142	155	155	35	35	142	142	142	142
		A-2	85	85	85	85	68	68	68	68	85	85	85	85
		B					オイルレベル Oil level	オイルレベル Oil level	オイルレベル Oil level	オイルレベル Oil level				
		B-1					43	147	147					
		B-2					68	68	68	68				
V面 V surface side		C											オイルレベル Oil level (W面に加工) (W surface only)	オイルレベル Oil level (W面に加工) (W surface only)
		C-1											135	135
		C-2												58
R面 R surface side		D												
		D-1												
		D-2												
		E	ドレン Drain RC1/2	ドレン Drain RC1/2	オイル栓 Oil plug RC1/2	オイル栓 Oil plug RC1/2					ドレン Drain RC1/2	ドレン Drain RC1/2	オイル栓 Oil plug RC1/2	オイル栓 Oil plug RC1/2
		E-1	95	95	95	95					95	95	95	95
		E-2	24	24	24	24					24	24	24	24
U面 U surface side		F							オイル栓 Oil plug RC3/8	オイル栓 Oil plug RC3/8				
		F-1							80	80				
		F-2							170	170				
		G	オイルレベル Oil level		オイルレベル Oil level						オイルレベル Oil level			
		G-1	60		60						60			
T面 T surface side		H					オイル栓 Oil plug RC3/8	オイル栓 Oil plug RC3/8						
		H-1					80	80						
		H-2					170	170						
		J		オイルレベル Oil level		オイルレベル Oil level					オイルレベル Oil level			
		J-1		60		60					60			
		J-2		125		125					125			

外形寸法 Dimensions

RA125

単位 Unit:mm

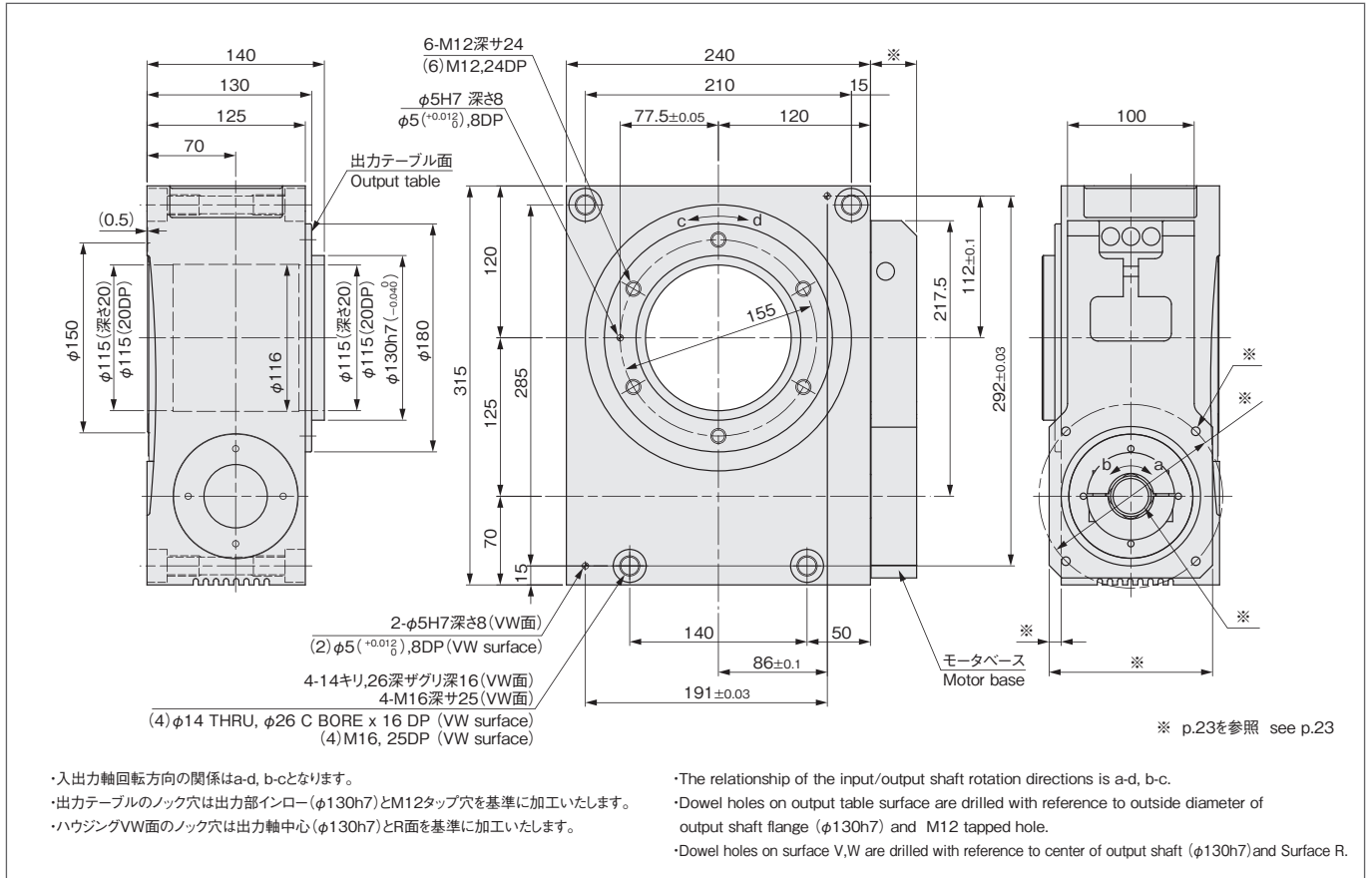

オイル栓、オイルレベル、ドレンの位置(オイル潤滑仕様の場合) Position of oil level and oil plug and drain (Case of oil lubrication)

単位 Unit:mm

視点 View from	取付姿勢 Mounting position	1		2		3		4		5		6		
View from	Motor position	T	U	T	U	T	U	T	U	T	U	T	U	
S面 S surface side		A	オイル栓 Oil plug RC1/2	オイル栓 Oil plug RC1/2	ドレン Drain RC1/2	ドレン Drain RC1/2	ドレン Drain RC1/2	ドレン Drain RC1/2	ドレン Drain RC1/2	ドレン Drain RC1/2	オイル栓 Oil plug RC1/2	オイル栓 Oil plug RC1/2	ドレン Drain RC1/2	ドレン Drain RC1/2
		A-1	180	180	180	180	200	200	40	40	180	180	180	180
		A-2	97	97	97	97	70	70	70	70	97	97	97	97
		B					オイルレベル Oil level	オイルレベル Oil level	オイルレベル Oil level	オイルレベル Oil level				
		B-1					60	60	180	180				
		B-2					70	70	70	70				
V面 V surface side		C										オイルレベル Oil level (W面に加工) (W surface only)	オイルレベル Oil level (W面に加工) (W surface only)	
		C-1										180	180	
		C-2										75	75	
R面 R surface side		D												
		D-1												
		D-2												
		E	ドレン Drain RC1/2	ドレン Drain RC1/2	オイル栓 Oil plug RC1/2	オイル栓 Oil plug RC1/2					ドレン Drain RC1/2	ドレン Drain RC1/2	オイル栓 Oil plug RC1/2	オイル栓 Oil plug RC1/2
		E-1	120	120	120	120					120	120	120	120
E-2	26	26	26	26					26	26	26	26		
U面 U surface side		F							オイル栓 Oil plug RC1/2	オイル栓 Oil plug RC1/2				
		F-1							80	80				
		F-2							245	245				
		G	オイルレベル Oil level		オイルレベル Oil level							オイルレベル Oil level		
		G-1	70		70							70		
G-2	140		140							140				
T面 T surface side		H					オイル栓 Oil plug RC1/2	オイル栓 Oil plug RC1/2						
		H-1					80	80						
		H-2					245	245						
		J		オイルレベル Oil level		オイルレベル Oil level						オイルレベル Oil level		
		J-1		70		70						70		
		J-2		140		140						140		