

## Dimensional drawing

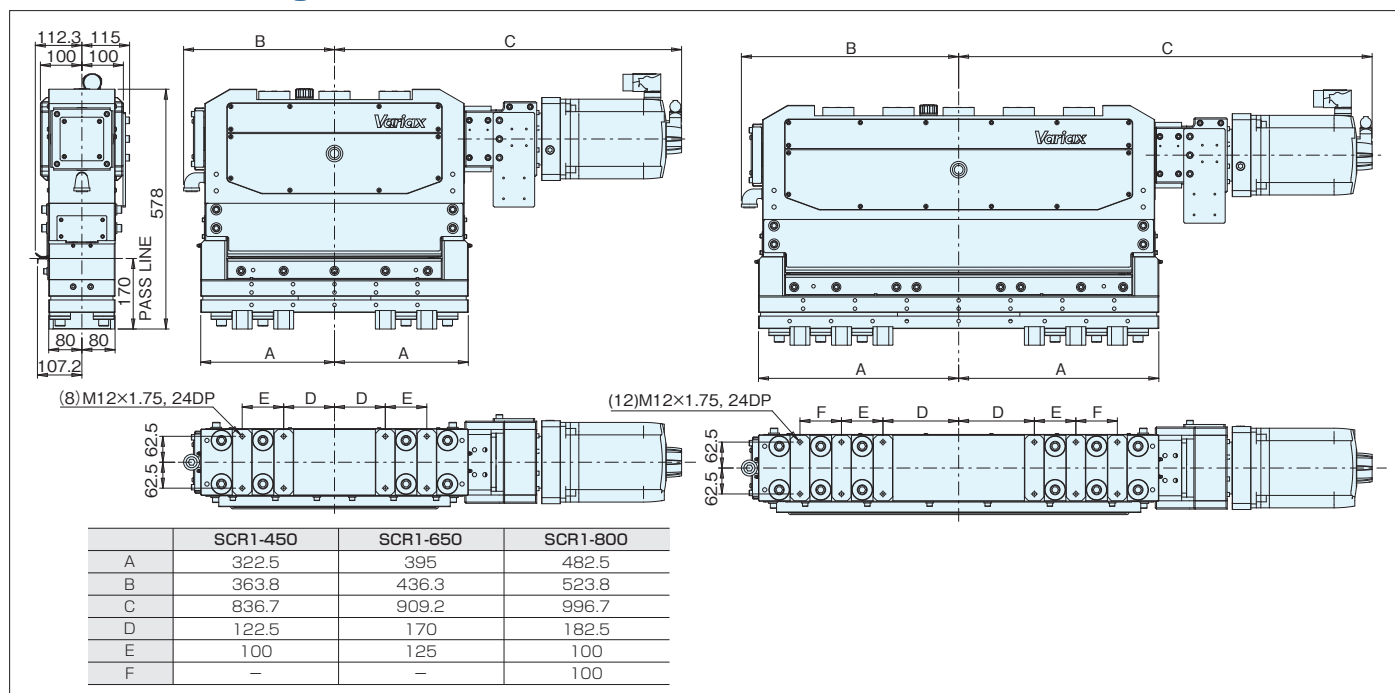

## Example of installation

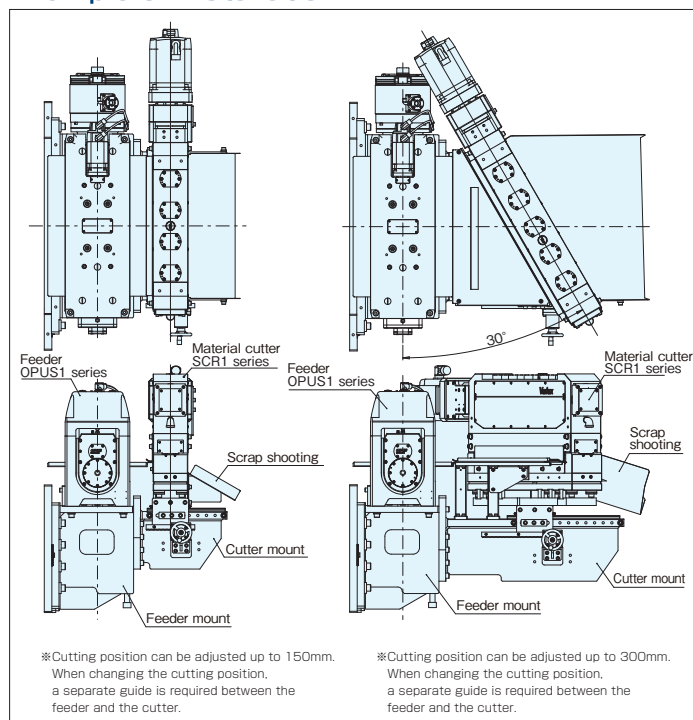

## Control panel dimensional drawings

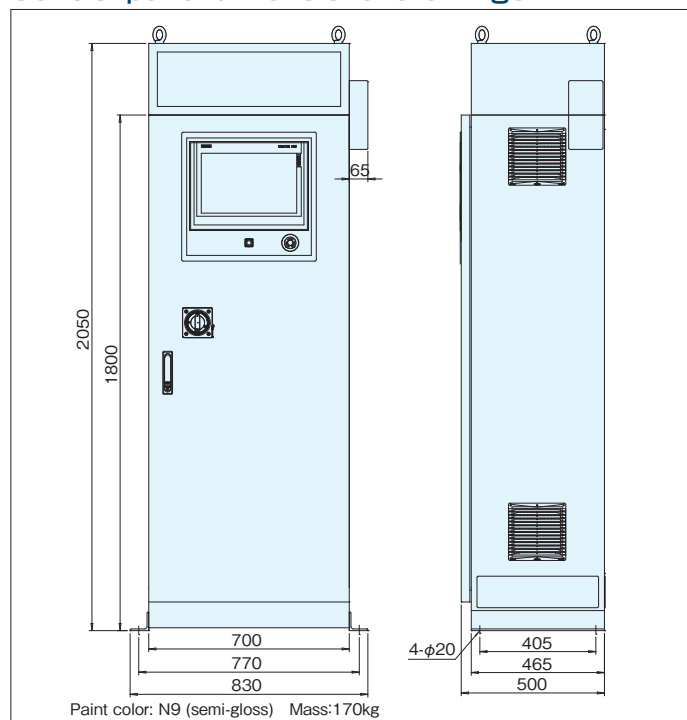

## Specification table

Item	Unit	SCR1-450	SCR1-650	SCR1-800	Remarks
Maximum cut material width	mm	450	650	800	
		345	470	620	When installed at an angle of 30°
		515	660	835	Cutter blade width
Material thickness	mm	0.1~0.5			
Cut off load	N	28,000	40,000	40,000	
Stripper load	N	2,400~3,600	3,600~5,500	3,600~5,500	
Synchronized speed	min <sup>-1</sup>	400			
Mass	kg	350	410	485	



■Headquarters (International Sales Division)  
3-37-3 Tabatashinmachi Kita-ku Tokyo Japan 114-8538  
Phone: +81-(0)3-3800-3305 Fax: +81-(0)3-3800-3378  
Email: overseas@sankyo-seisakusho.co.jp

■Sankyo Korea Co., Ltd.  
Phone: +82-(0)31-895-5991 Email: kr-sales@rollerdrive.com

■Sankyo Seisakusho Co. Taiwan Branch  
Phone: +886-(0)4-2359-4048 Email: tw-sales@rollerdrive.com

■Sankyo Works (Thailand) Co., Ltd.  
Phone: +66-(0)2-516-5355 Email: sales@sankyo-works.co.th

■Sankyo America Inc.  
Phone: +1-(0)937-498-4901  
Email: sales@sankyoautomation.com

■Sankyo China Trading Co., Ltd.  
Phone: +86-(0)21-5445-2813  
Email: sales@sankyochina-trading.com